

Technical Specifications

Agilent Technologies
PNA Series Network Analyzers
N5230A
Options 240/245
(4-Port PNA)



Manufacturing Part Number: N5230-90020

Printed in USA

Print Date: October 28, 2005

Supersedes: June, 2005

© Agilent Technologies, Inc. 2004, 2005

Documentation Warranty

THE MATERIAL CONTAINED IN THIS DOCUMENT IS PROVIDED "AS IS," AND IS SUBJECT TO BEING CHANGED, WITHOUT NOTICE, IN FUTURE EDITIONS. FURTHER, TO THE MAXIMUM EXTENT PERMITTED BY APPLICABLE LAW, AGILENT DISCLAIMS ALL WARRANTIES, EITHER EXPRESS OR IMPLIED WITH REGARD TO THIS MANUAL AND ANY INFORMATION CONTAINED HEREIN, INCLUDING BUT NOT LIMITED TO THE IMPLIED WARRANTIES OF MERCHANTABILITY AND FITNESS FOR A PARTICULAR PURPOSE. AGILENT SHALL NOT BE LIABLE FOR ERRORS OR FOR INCIDENTAL OR CONSEQUENTIAL DAMAGES IN CONNECTION WITH THE FURNISHING, USE, OR PERFORMANCE OF THIS DOCUMENT OR ANY INFORMATION CONTAINED HEREIN. SHOULD AGILENT AND THE USER HAVE A SEPARATE WRITTEN AGREEMENT WITH WARRANTY TERMS COVERING THE MATERIAL IN THIS DOCUMENT THAT CONFLICT WITH THESE TERMS, THE WARRANTY TERMS IN THE SEPARATE AGREEMENT WILL CONTROL.

DFARS/Restricted Rights Notice

If software is for use in the performance of a U.S. Government prime contract or subcontract, Software is delivered and licensed as "Commercial computer software" as defined in DFAR 252.227-7014 (June 1995), or as a "commercial item" as defined in FAR 2.101(a) or as "Restricted computer software" as defined in FAR 52.227-19 (June 1987) or any equivalent agency regulation or contract clause. Use, duplication or disclosure of Software is subject to Agilent Technologies' standard commercial license terms, and non-DOD Departments and Agencies of the U.S. Government will receive no greater than Restricted Rights as defined in FAR 52.227-19(c)(1-2) (June 1987). U.S. Government users will receive no greater than Limited Rights as defined in FAR 52.227-14 (June 1987) or DFAR 252.227-7015 (b)(2) (November 1995), as applicable in any technical data.

Printing Copies of Documentation from the Web

To print copies of documentation from the Web, download the PDF file from the Agilent web site:

- Go to <http://www.agilent.com>.
 - Enter the document's part number (located on the title page) in the **Quick Search** box.
 - Click GO.
 - Click on the hyperlink for the document.
 - Click the printer icon located in the tool bar.
-

Contacting Agilent

This information supersedes all prior HP contact information.

Online assistance: www.agilent.com/find/assist

Americas			
Brazil <i>(tel)</i> (+55) 11 3351 7012 <i>(fax)</i> (+55) 11 3351 7024	Canada <i>(tel)</i> +1 877 894 4414 <i>(alt)</i> +1 303 662 3369 <i>(fax)</i> +1 800 746 4866	Mexico <i>(tel)</i> 1 800 254 2440 <i>(fax)</i> 1 800 254 4222	United States <i>(tel)</i> 800 829 4444 <i>(alt)</i> (+1) 303 662 3998 <i>(fax)</i> 800 829 4433
Asia Pacific and Japan			
Australia <i>(tel)</i> 1 800 802 540 <i>(fax)</i> 1 800 681 776 <i>(fax)</i> 1 800 225 539	China <i>(tel)</i> 800 810 0508 <i>(fax)</i> 800 810 0507	Hong Kong <i>(tel)</i> 800 933 229 <i>(fax)</i> 800 900 701	India <i>(tel)</i> 1600 112 626 <i>(fax)</i> 1600 113 040
Japan (Bench) <i>(tel)</i> 0120 421 345 <i>(alt)</i> (+81) 426 56 7832 <i>(fax)</i> 0120 01 2144	Japan (On-Site) <i>(tel)</i> 0120 421 345 <i>(alt)</i> (+81) 426 56 7832 <i>(fax)</i> 0120 012 114	Singapore <i>(tel)</i> 1 800 275 0880 <i>(fax)</i> (+65) 6755 1214	South Korea <i>(tel)</i> 080 778 0011 <i>(fax)</i> 080 778 0013
Taiwan <i>(tel)</i> 0800 047 669 <i>(fax)</i> 0800 047 667 <i>(fax)</i> 886 3492 0779	Thailand <i>(tel)</i> 1 800 2758 5822 <i>(fax)</i> 1 800 656 336	Malaysia <i>(tel)</i> 1800 880 399 <i>(fax)</i> 1800 801 054	
Europe			
Austria <i>(tel)</i> 0820 87 44 11* <i>(fax)</i> 0820 87 44 22	Belgium <i>(tel)</i> (+32) (0)2 404 9340 <i>(fax)</i> (+32) (0)2 404 9395	Denmark <i>(tel)</i> (+45) 7013 1515 <i>(fax)</i> (+45) 7013 1555	Finland <i>(tel)</i> (+358) 10 855 2100 <i>(fax)</i> (+358) (0) 10 855 2923
France <i>(tel)</i> 0825 010 700* <i>(fax)</i> 0825 010 701*	Germany <i>(tel)</i> 01805 24 6333* <i>(fax)</i> 01805 24 6336*	Ireland <i>(tel)</i> (+353) (0)1 890 924 204 <i>(fax)</i> (+353) (0)1 890 924 024	Israel <i>(tel)</i> (+972) 3 9288 504 <i>(alt)</i> (+972) 3 9288 544 <i>(fax)</i> (+972) 3 9288 520
Italy <i>(tel)</i> (+39) (0)2 9260 8484 <i>(fax)</i> (+39) (0)2 9544 1175	Luxemburg <i>(tel)</i> (+32) (0)2 404 9340 <i>(fax)</i> (+32) (0)2 404 9395	Netherlands <i>(tel)</i> (+31) (0)20 547 2111 <i>(fax)</i> (+31) (0)20 547 2190	Russia <i>(tel)</i> (+7) 095 797 3963 <i>(alt)</i> (+7) 095 797 3900 <i>(fax)</i> (+7) 095 797 3902
Spain <i>(tel)</i> (+34) 91 631 3300 <i>(fax)</i> (+34) 91 631 3301	Sweden <i>(tel)</i> 0200 88 22 55* <i>(alt)</i> (+46) (0)8 5064 8686 <i>(fax)</i> 020 120 2266*	Switzerland (French) <i>(tel)</i> 0800 80 5353 opt. 2* <i>(fax)</i> (+41) (0)22 567 5313	Switzerland (German) <i>(tel)</i> 0800 80 5353 opt. 1* <i>(fax)</i> (+41) (0)1 272 7373
Switzerland (Italian) <i>(tel)</i> 0800 80 5353 opt. 3* <i>(fax)</i> (+41) (0)22 567 5314	United Kingdom <i>(tel)</i> (+44) (0)7004 666666 <i>(fax)</i> (+44) (0)7004 444555		
<i>(tel)</i> = primary telephone number; <i>(alt)</i> = alternate telephone number; <i>(fax)</i> = FAX number; * = in country number 5/6/05			

This page intentionally left blank.

Technical Specifications for the N5230A

Options 240 and 245 (4-Port PNA-L) (N5230-90020, Rev. 2005-10-28)

DEFINITIONS	3
Corrected System Performance	4
Table 1. System Dynamic Range at Test Port	4
Table 2. Extended Dynamic Range at Direct Receiver Access Input	4
N5230A Corrected System Performance with 3.5mm Connectors	5
Table 3. 85052B Calibration Kit N5230A - Option 240 (Standard Test Set and Standard Power Range)	5
Table 4. 85052B Calibration Kit N5230A - Option 245 (Configurable Test Set and Extended Power Range)	8
Table 5. N4691A Electronic Calibration Module N5230A - Option 240 (Standard Test Set and Standard Power Range)	11
Table 6. N4691A Electronic Calibration Module N5230A - Option 245 (Configurable Test Set and Extended Power Range)	14
Table 7. Uncorrected System Performance	17
Table 8. Test Port Output	18
Table 9. Test Port Input.....	20
Table 10. Dynamic Accuracy (Specification)	23
Table 11. Test Port Input (Group Delay)	28
General Information	29
Table 12. Miscellaneous Information	29
Table 13. Front Panel Information.....	29
Table 14. Rear Panel Information.....	30
Table 15. Analyzer Environment and Dimensions	31
Measurement Throughput Summary	32
Table 16 Typical Cycle Time (ms) for Measurement Completion.....	32
Table 17. Cycle Time vs IF Bandwidth	33
Table 18. Cycle Time vs Number of Points.....	34
Table 19. Data Transfer Time (ms).....	35
Specifications: Front-Panel Jumpers	36
Table 20: Measurement Receiver Inputs (Rcvr A In, Rcvr B In, Rcvr C In, Rcvr D In) 0.1dB Typical Compression	36
Table 21: Reference Receiver Input (Rcvr In) @ Max Specified Output Power	36
Table 22: Reference Output (Source Out) @ Max Specified Output Power.....	37
Table 23: Source Outputs (Port 1 Source Out, Port 2 Source Out, Port 3 Source Out, Port 4 Source Out) @ Max Specified Output Power.....	37
Table 24: Coupler Inputs (Port 1 Cplr Thru, Port 2 Cplr Thru, Port 3 Cplr Thru, Port 4 Cplr Thru) Insertion Loss of Coupler Thru.....	38

Table 25: Coupler Outputs (Port 1 Cplr Arm, Port 2 Cplr Arm, Port 3 Cplr Arm, Port 4 Cplr Arm)	38
Test Set Block Diagrams	39
N5230A Option 240 (Standard Test Set and Standard Power Range)	39
N5230A Option 245 (Configurable Test Set and Extended Power Range)	40

This is a complete list of the N5230A Options 240, 245 network analyzer technical specifications.

- To view or print the .pdf version of the specifications, visit our web site at <http://www.agilent.com/find/pna>, and search for "N5230A Options 240 and 245 Specifications"
- This N5230A document provides technical specifications for the 85052B calibration kit and the N4691A ECal module. Please download our free Uncertainty Calculator from http://www.agilent.com/find/na_calculator to generate the curves for your calibration kit and PNA setup.

Definitions

All specifications and characteristics apply over a 25 °C \pm 5 °C range (unless otherwise stated) and 90 minutes after the instrument has been turned on.

Specification (spec.): Warranted performance. Specifications include guardbands to account for the expected statistical performance distribution, measurement uncertainties, and changes in performance due to environmental conditions.

Characteristic (char.): A performance parameter that the product is expected to meet before it leaves the factory, but that is not verified in the field and is not covered by the product warranty. A characteristic includes the same guardbands as a specification.

Typical (typ.): Expected performance of an average unit which does not include guardbands. It is not covered by the product warranty.

Nominal (nom.): A general, descriptive term that does not imply a level of performance. It is not covered by the product warranty.

Calibration: The process of measuring known standards to characterize a network analyzer's systematic (repeatable) errors.

Corrected (residual): Indicates performance after **error correction** (calibration). It is determined by the quality of calibration standards and how well "known" they are, plus system repeatability, stability, and noise.

Uncorrected (raw): Indicates instrument performance without error correction. The uncorrected performance affects the stability of a **calibration**.

Standard: When referring to the analyzer, this includes no options unless noted otherwise.

Corrected System Performance

The specifications in this section apply for measurements made with the N5230A analyzer with the following conditions:

- 10 Hz IF bandwidth
- No averaging applied to data
- Isolation calibration with an averaging factor of 8

Table 1. System Dynamic Range at Test Port¹

Description	Specification (dB) at Test Port	Typical (dB) at Test Port
Standard configuration and standard power range (Option 240)		
300 KHz to 10 MHz ²	--	111 dB
10 MHz to 4 GHz ²	120 dB	128 dB
4 GHz to 6 GHz	118 dB	129 dB
6 GHz to 10.5 GHz	115 dB	127 dB
10.5 GHz to 15 GHz	107 dB	119 dB
15 GHz to 20 GHz	103 dB	116 dB
Configurable test set and extended power range (Option 245)		
300 KHz to 10 MHz ²	--	111 dB
10 MHz to 4 GHz ²	120 dB	128 dB
4 GHz to 6 GHz	118 dB	128 dB
6 GHz to 10.5 GHz	113 dB	125 dB
10.5 GHz to 15 GHz	105 dB	117 dB
15 GHz to 20 GHz	98 dB	115 dB

¹ The system dynamic range is calculated as the difference between the noise floor and the specified source maximum output power. The effective dynamic range must take measurement uncertainties and interfering signals into account.

² May be degraded by 10 dB at particular frequencies (multiples of 5 MHz) below 500 MHz due to spurious receiver residuals. Methods are available to regain the full dynamic range.

Table 2. Extended Dynamic Range at Direct Receiver Access Input¹

Configurable test set and extended power range (Option 245)		
	Specification (dB)	Typical (dB)
300 KHz to 10 MHz ²	--	127 dB
10 MHz to 4 GHz ²	136 dB	--
4 GHz to 6 GHz	134 dB	--
6 GHz to 10.5 GHz	129 dB	--
10.5 GHz to 15 GHz	121 dB	--
15 GHz to 20 GHz	114 dB	--

¹ The direct receiver access input extended dynamic range is calculated as the difference between the direct receiver access input noise floor and the source maximum output power. The effective dynamic range must take measurement uncertainties and interfering signals into account. This set-up should only be used when the receiver input will never exceed its compression or damage level. When the analyzer is in segment sweep mode, it can have predefined frequency segments which will output a higher power level when the extended dynamic range is required (i.e. devices with high insertion loss), and reduced power when receiver compression or damage may occur (i.e. devices with low insertion loss). The extended range is only available in one-path transmission measurements.

² May be degraded by 10 dB at particular frequencies (multiples of 5 MHz) below 500 MHz due to spurious receiver residuals. Methods are available to regain the full dynamic range.

Receiver Dynamic Range technical specifications are not provided in this N5230A specs document.

N5230A Corrected System Performance with 3.5mm Connectors¹

Options 240/245

¹ From 300 kHz to 10 MHz, performance is characterized as "typical". To generate these typical values, please download our free Uncertainty Calculator from http://www.agilent.com/find/na_calculator.

Note: For any S_{ii} reflection measurement:

- $S_{ij} = 0$.

For any S_{ij} transmission measurement:

- $S_{ji} = S_{ij}$ when $S_{ij} \leq 1$
- $S_{ji} = 1/S_{ij}$ when $S_{ij} \geq 1$
- $S_{kk} = 0$ for all k

**Table 3. 85052B Calibration Kit
N5230A - Option 240 (Standard Test Set and Standard Power Range)**

Applies to the, N5230A Option 240 analyzers, 85052B (3.5mm) calibration kit, 85131F flexible test port cable set, and a full 2-port calibration. Also applies to the following condition:

Environmental temperature $23^\circ \pm 3^\circ \text{C}$, with $< 1^\circ \text{C}$ deviation from calibration temperature

Description	Specification (dB)			
	10 MHz to 500 MHz	500 MHz to 2 GHz	2 to 8 GHz	8 to 20 GHz
Directivity	48	48	44	44
Source Match	40	40	33	31
Load Match	48	48	44	44
Reflection Tracking	± 0.003 $+0.010/^\circ\text{C}$	± 0.003 $+0.010/^\circ\text{C}$	± 0.003 $+0.020/^\circ\text{C}$	± 0.006 $+0.030/^\circ\text{C}$
Transmission Tracking	± 0.017 $+0.010/^\circ\text{C}$	± 0.017 $+0.010/^\circ\text{C}$	± 0.062 $+0.020/^\circ\text{C}$	± 0.125 $+0.030/^\circ\text{C}$

Transmission Uncertainty (Specifications)

Magnitude

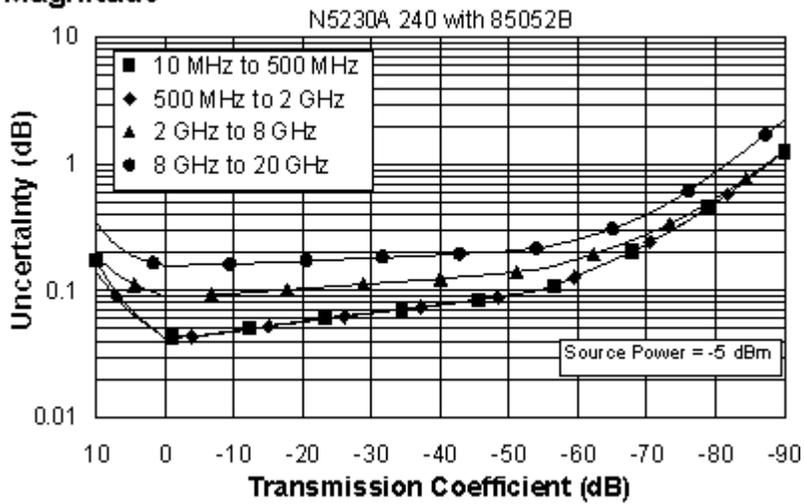

Phase

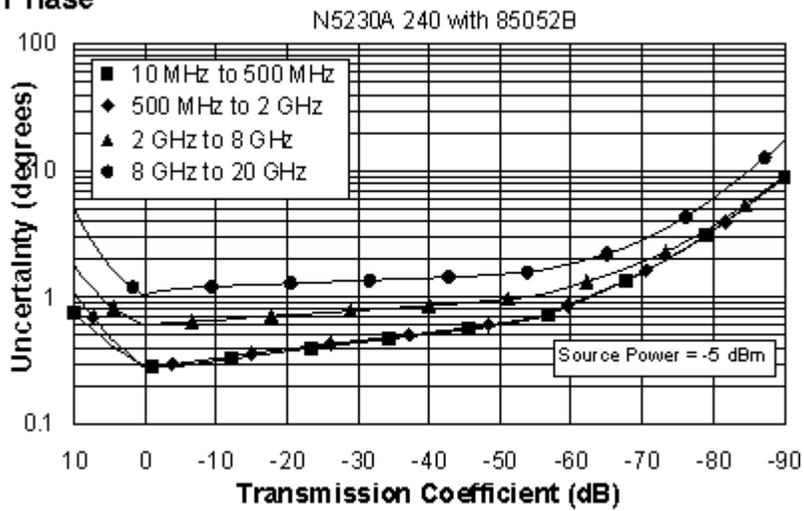

Reflection Uncertainty (Specifications)

Magnitude

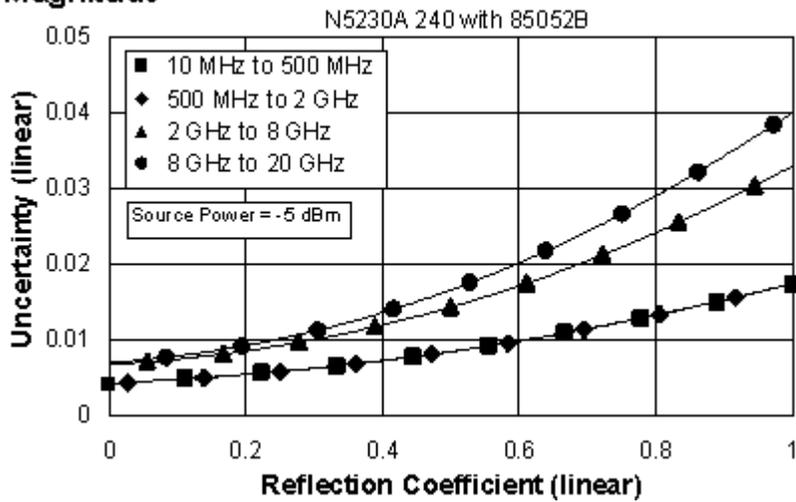

Phase

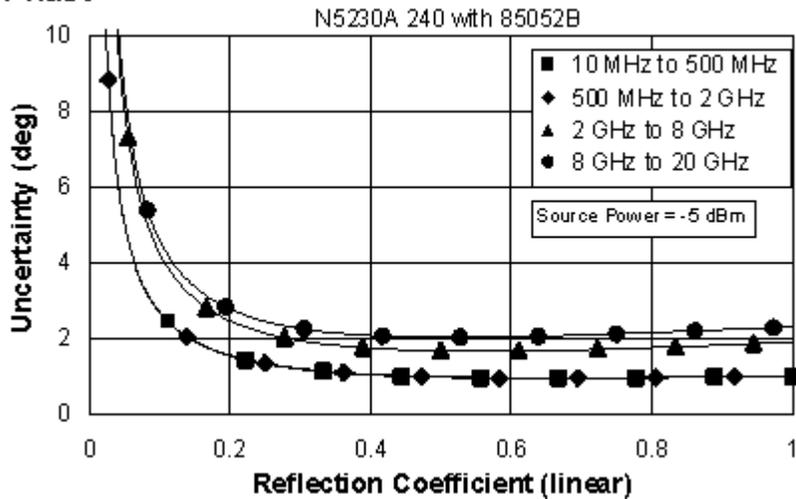

**Table 4. 85052B Calibration Kit
N5230A - Option 245 (Configurable Test Set and Extended Power Range)**

Applies to the, N5230A Option 245 analyzers, 85052B (3.5mm) calibration kit, 85131F flexible test port cable set, and a full 2-port calibration. Also applies to the following condition:

Environmental temperature 23° ±3 °C, with < 1 °C deviation from calibration temperature

Description	Specification (dB)			
	10 MHz to 500 MHz	500 MHz to 2 GHz	2 to 8 GHz	8 to 20 GHz
Directivity	48	48	44	44
Source Match	40	40	33	31
Load Match	48	48	44	44
Reflection Tracking	±0.003 +0.010/°C	±0.003 +0.010/°C	±0.003 +0.020/°C	±0.006 +0.030/°C
Transmission Tracking	±0.017 +0.010/°C	±0.017 +0.010/°C	±0.062 +0.020/°C	±0.125 +0.030/°C

Transmission Uncertainty (Specifications)

Magnitude

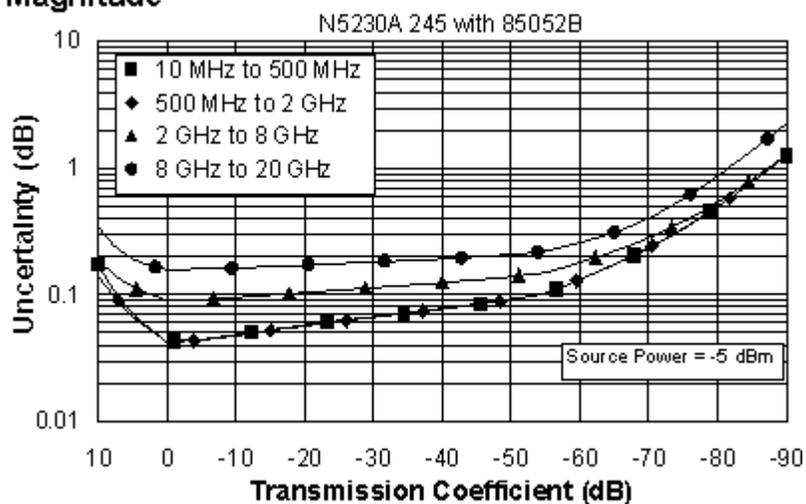

Phase

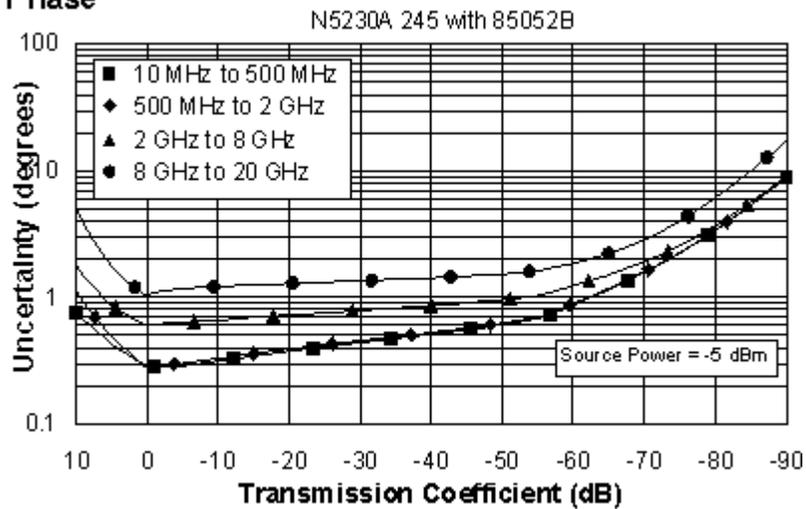

Reflection Uncertainty (Specifications)

Magnitude

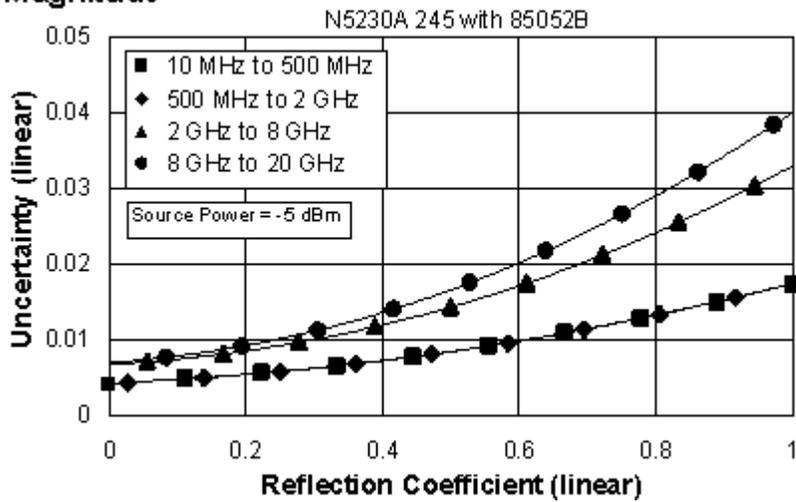

Phase

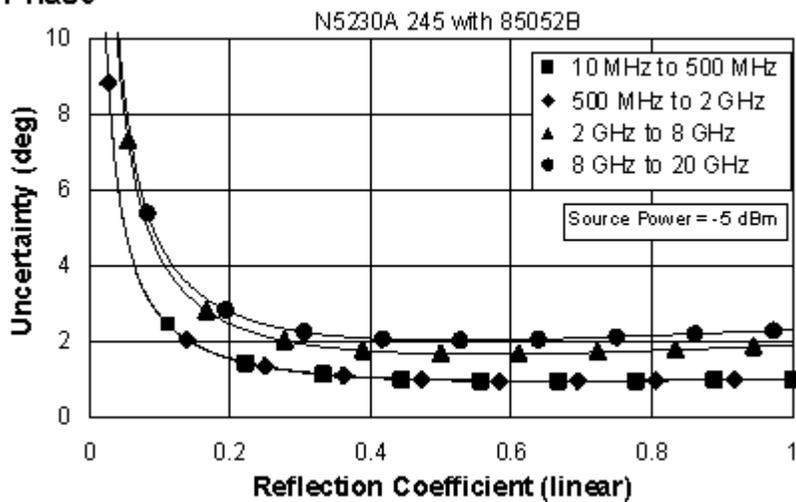

**Table 5. N4691A Electronic Calibration Module
N5230A - Option 240 (Standard Test Set and Standard Power Range)**

Applies to the, N5230A Option 240 analyzers, N4691A (3.5mm) electronic calibration module, 85131F flexible test port cable set, and a full 2-port calibration. Also applies to the following condition:

Environmental temperature $23^{\circ} \pm 3^{\circ} \text{C}$, with $< 1^{\circ} \text{C}$ deviation from calibration temperature

Description	Specification (dB)			
	45 MHz to 500 MHz	500 MHz to 2 GHz	2 to 8 GHz	8 to 20 GHz
Directivity	56	56	54	49
Source Match	47	47	45	44
Load Match	46	46	45	43
Reflection Tracking	± 0.050 $+0.010/^{\circ}\text{C}$	± 0.050 $+0.010/^{\circ}\text{C}$	± 0.070 $+0.020/^{\circ}\text{C}$	± 0.090 $+0.030/^{\circ}\text{C}$
Transmission Tracking	± 0.055 $+0.010/^{\circ}\text{C}$	± 0.056 $+0.010/^{\circ}\text{C}$	± 0.057 $+0.020/^{\circ}\text{C}$	± 0.071 $+0.030/^{\circ}\text{C}$

Transmission Uncertainty (Specifications)

Magnitude

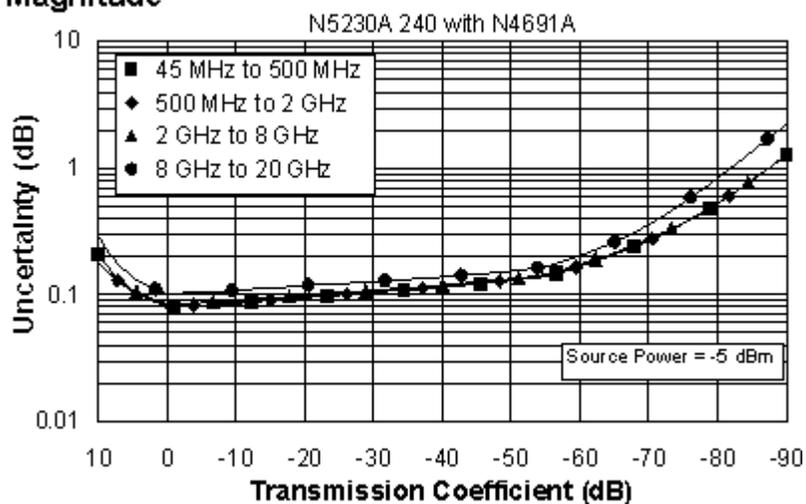

Phase

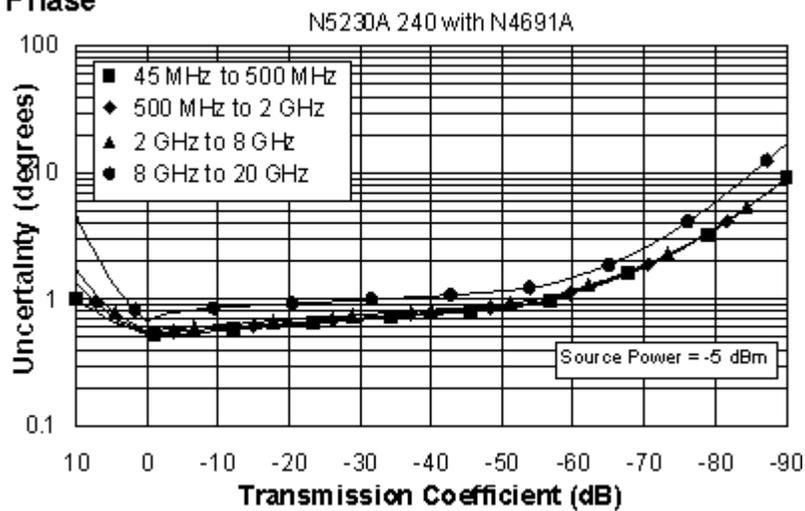

Reflection Uncertainty (Specifications)

Magnitude

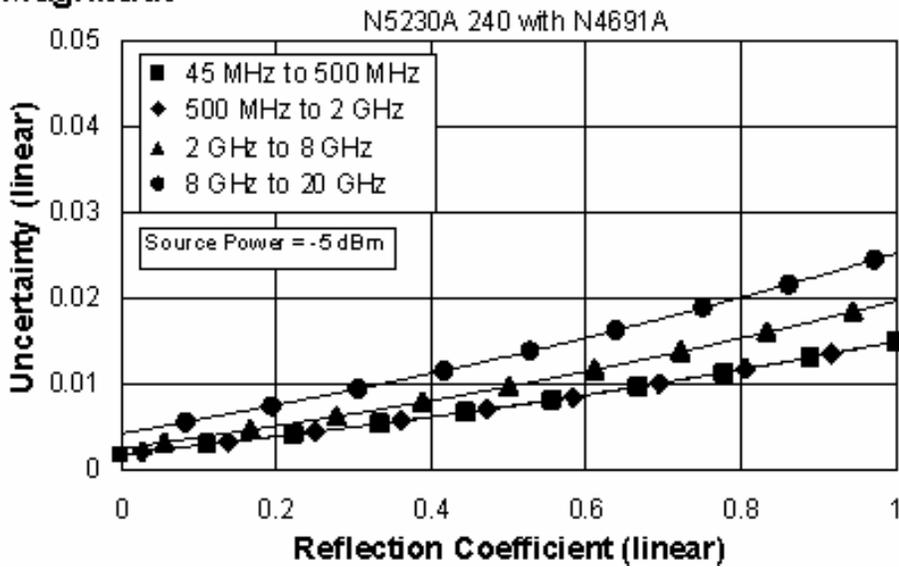

Phase

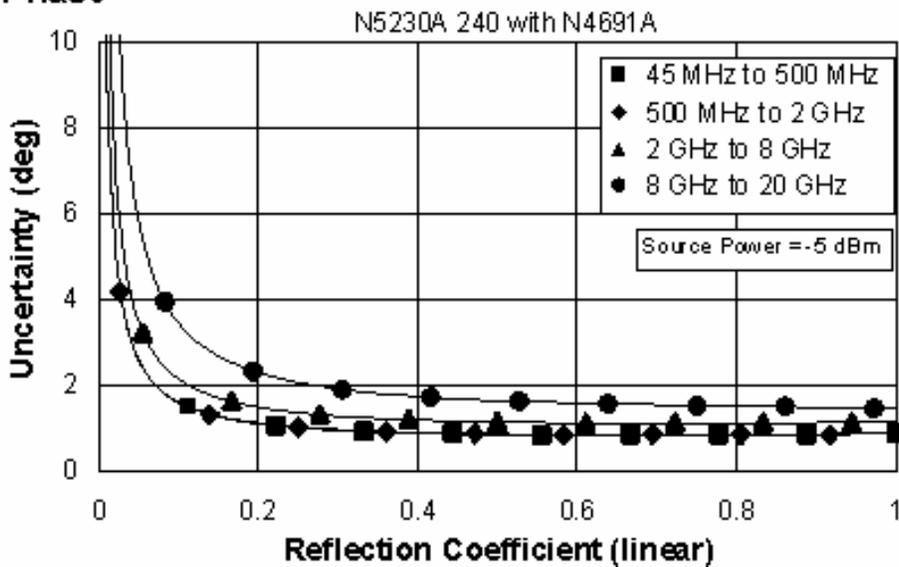

**Table 6. N4691A Electronic Calibration Module
N5230A - Option 245 (Configurable Test Set and Extended Power Range)**

Applies to the, N5230A Option 245 analyzers, N4691A (3.5 mm) Electronic Calibration Module, 85131F flexible test port cable set, and a full 2-port calibration. Also applies to the following condition:

Environmental temperature 23° ±3 °C, with < 1 °C deviation from calibration temperature

Description	Specification (dB)			
	45 MHz to 500 MHz	500 MHz to 2 GHz	2 to 8 GHz	8 to 20 GHz
Directivity	56	56	54	49
Source Match	47	47	45	44
Load Match	46	46	45	43
Reflection Tracking	±0.050 +0.010/°C	±0.050 +0.010/°C	±0.070 +0.020/°C	±0.090 +0.030/°C
Transmission Tracking	±0.055 +0.010/°C	±0.056 +0.010/°C	±0.057 +0.020/°C	±0.071 +0.030/°C

Transmission Uncertainty (Specifications)

Magnitude

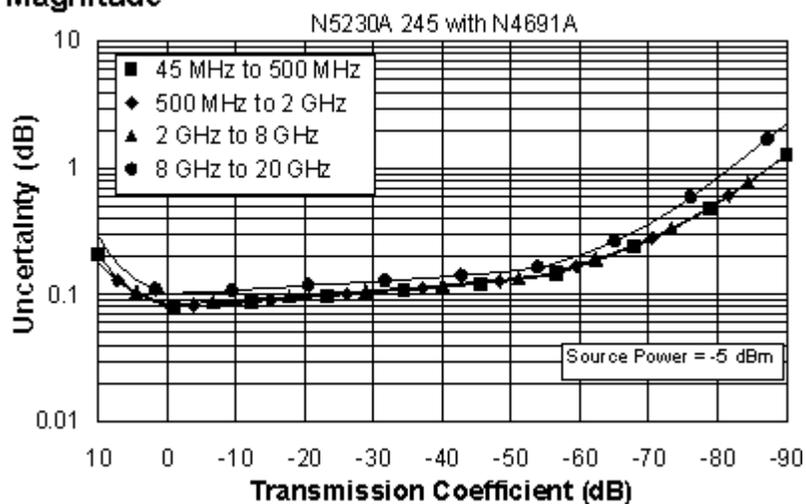

Phase

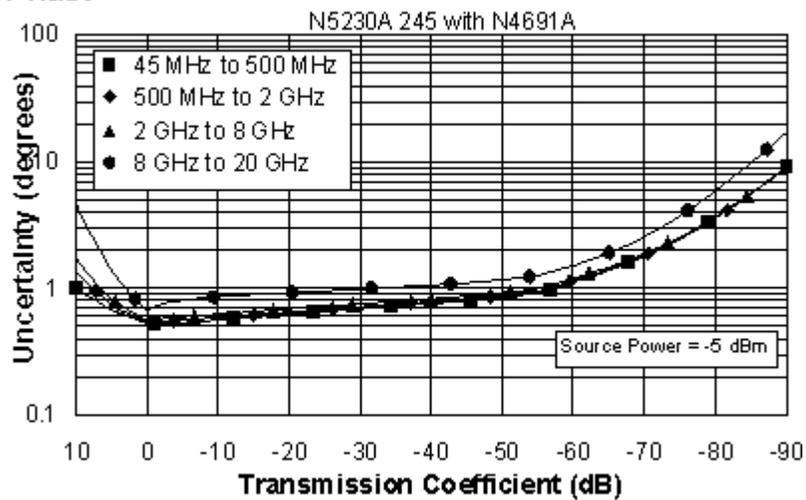

Reflection Uncertainty (Specifications)

Magnitude

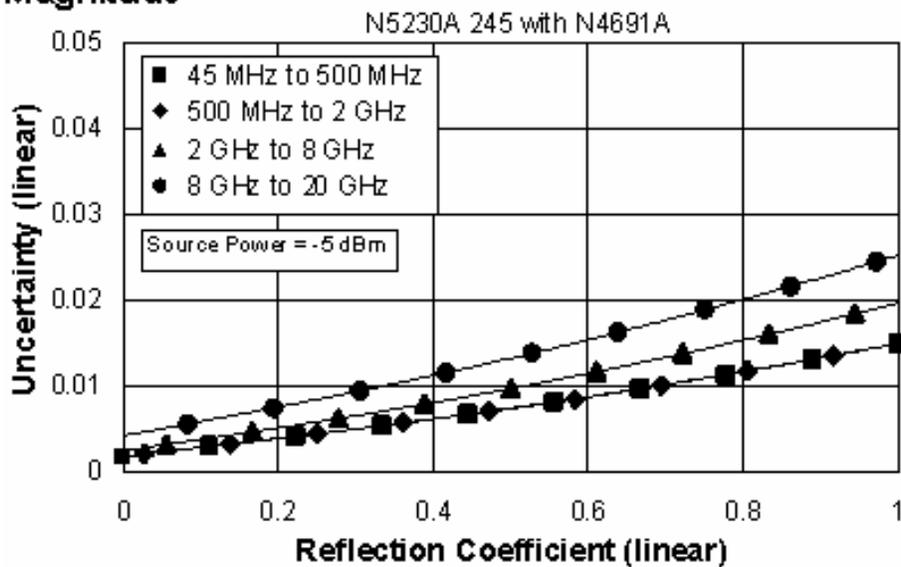

Phase

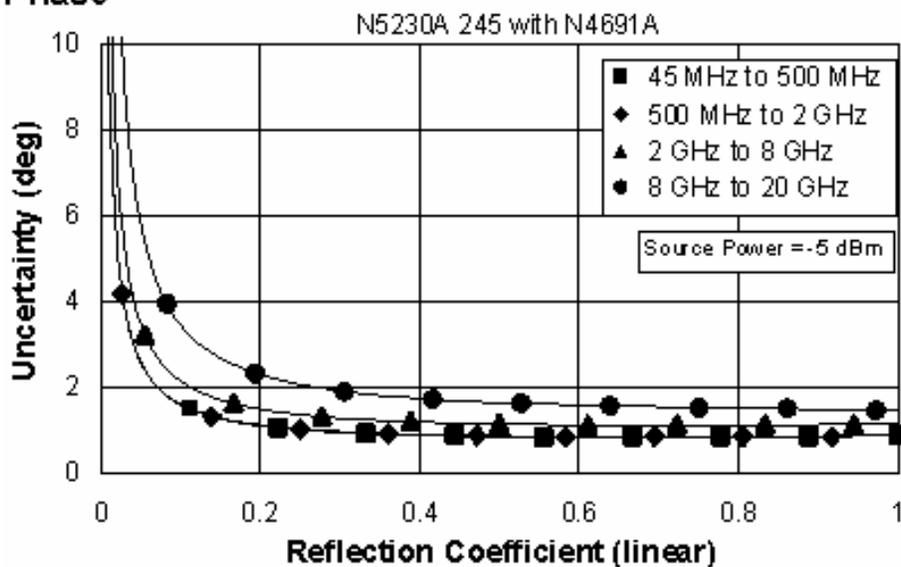

This N5230A document does not present specifications for the 85052C or 85052D Calibration Kit. Please download our free Uncertainty Calculator from http://www.agilent.com/find/na_calculator to generate the data and curves for the 85052C or the 85052D Calibration Kit. View the [equations](#) used to generate the uncertainty curves.

Table 7. Uncorrected System Performance¹

Description	Specification	Typical
	Options 240, 245	Options 240, 245
Directivity		
300 KHz to 10 MHz	--	-23 dB
10 MHz to 1 GHz	-28 dB	--
1 GHz to 3 GHz	-25 dB	--
3 GHz to 5 GHz	-20 dB	--
5 GHz to 11.5 GHz	-17 dB	--
11.5 GHz to 20 GHz	-15 dB	--
Source Match		
300 KHz to 10 MHz	--	-8 dB
10 MHz to 1 GHz	-12 dB	--
1 GHz to 3 GHz	-12 dB	--
3 GHz to 5 GHz	-12 dB	--
5 GHz to 10.5 GHz	-12 dB	--
10.5 GHz to 11.5 GHz	-10 dB	--
11.5 GHz to 20 GHz	-8 dB	--
Load Match		
300 KHz to 10 MHz	--	-9 dB
10 MHz to 1 GHz	-20 dB	--
1 GHz to 3 GHz	-20 dB	--
3 GHz to 5 GHz	-18 dB	--
5 GHz to 11.5 GHz	-12 dB	--
11.5 GHz to 16 GHz	-7 dB	--
16 GHz to 20 GHz	-7.5 dB	--
Crosstalk²		
300 KHz to 5 MHz	--	-70 dB
5 MHz to 10 MHz	--	-100 dB
10 MHz to 45 MHz	--	-110 dB
45 MHz to 4 GHz	--	-122 dB
4 GHz to 6 GHz	--	-123 dB
6 GHz to 10.5 GHz	--	-120 dB
10.5 GHz to 15 GHz	--	-115 dB
15 GHz to 20 GHz	--	-110 dB

¹ Specifications apply over environmental temperature of 25 °C ±5 °C, with less than 1°C variation from the calibration temperature.

² Measurement conditions: normalized to a thru, measured with two shorts, 10 Hz IF bandwidth, averaging factor of 8, alternate mode, source power set to the lesser of the maximum power out or the maximum receiver power.

Table 8. Test Port Output¹

Description	Specification		Typical	
	Opt 240	Opt 245	Opt 240	Opt 245
Frequency Range				
	300 KHz to 20 GHz		--	
Nominal Power				
	-5 dBm	-8 dBm	Preset power; attenuator switch point 10 dB below nominal power	
Frequency Resolution				
	1 Hz		--	
CW Accuracy				
	+/-1 ppm		--	
Frequency Stability				
	--		+/-0.05 ppm. -10° to 70° C +/-0.1 ppm/yr maximum	
Description	Specification		Typical	
	Opt 240	Opt 245	Opt 240	Opt 245
Power Level Accuracy				
Variation from nominal power in range 0				
300 KHz to 10 MHz	--	--	+/-1.0 dB	+/-1.0 dB
10 MHz to 2 GHz	+/-1.0 dB	+/-1.0 dB	--	--
2 GHz to 10.5 GHz	+/-1.5 dB	+/-1.5 dB	--	--
10.5 GHz to 20 GHz	+/-2.5 dB	+/-2.5 dB	--	--
Max Leveled Power				
300 KHz to 10 MHz	--	--	+8 dBm	+8 dBm
10 MHz to 4 GHz	+8 dBm	+8 dBm	+12 dBm	+11 dBm
4 GHz to 6 GHz	+6 dBm	+6 dBm	+10 dBm	+9 dBm
6 GHz to 10.5 GHz	+3 dBm	+1 dBm	+8 dBm	+6 dBm
10.5 GHz to 15 GHz	0 dBm	-2 dBm	+5 dBm	+3 dBm
15 GHz to 20 GHz	-3 dBm	-8 dBm	+2 dBm	-1 dBm
Power Level Linearity				
Specified on Port 1 only. Ports 2, 3, 4 performance is Typical. Test reference is at the nominal power level.				
300 KHz to 10 MHz	--	--	+/-2.0 dB	+/-2.0 dB
10 MHz to 1 GHz	+/-2.0 dB	+/-2.0 dB	--	--
1 GHz to 20 GHz	+/-1.5 dB	+/-1.5 dB	--	--
Power Sweep Range (ALC)				
ALC range starts at maximum-leveled power and decreases by the dB amount specified here.				
300 KHz to 10 MHz	--	--	35 dB	35 dB
10 MHz to 4 GHz	33 dB	33 dB	--	--
4 GHz to 6 GHz	31 dB	31 dB	--	--
6 GHz to 10.5 GHz	28 dB	26 dB	--	--
10.5 GHz to 15 GHz	25 dB	23 dB	--	--
15 GHz to 20 GHz	22 dB	17 dB	--	--

Table 8. Test Port Output (Continued)

Description	Specification		Typical	
	Opt 240	Opt 245	Opt 240	Opt 245
Power Resolution				
	0.01 dB	0.01 dB	--	--
Power Range				
300 KHz to 10 MHz	--	--	-27 to +8 dBm	-87 to +8 dBm
10 MHz to 45MHz	--	--	-27 to +12 dBm	-87 to +11 dBm
45 MHz to 4 GHz	--	--	-27 to +12 dBm	-87 to +11 dBm
4 GHz to 6 GHz	--	--	-27 to +10 dBm	-87 to +9 dBm
6 GHz to 10.5 GHz	--	--	-27 to +8 dBm	-87 to +6 dBm
10.5 GHz to 15 GHz	--	--	-27 to +5 dBm	-87 to +3 dBm
15 GHz to 20 GHz	--	--	-27 to +2 dBm	-87 to -1 dBm
Power Settings				
Minimum Power Setting	--	--	-30 dBm	-90 dBm
Maximum Power Setting	--	--	+20 dBm	+20 dBm
Harmonics (2nd or 3rd) at Maximum Output Power				
In-band Source Harmonics				
300 KHz to 10 MHz	--	--	-17 dBc	
10 MHz to 1 GHz	--	--	-17 dBc	
1 GHz to 20 GHz	--	--	-20 dBc	
Non-Harmonic Spurious (at Nominal Output Power)				
300 KHz to 20 GHz	--	--	-50 dBc for offset frequency > 1 KHz	

¹ Performance specified on Port 1 only; Ports 2, 3, and 4 performance is typical. Test reference is at the nominal power level.

Table 8. Test Port Output (Continued)

Phase Noise (Nominal power at test port)	Typical Performance		
	10 kHz Offset	100 kHz Offset	1 MHz Offset
300 KHz to 10 MHz	-86 dBc/Hz	-86 dBc/Hz	-95 dBc/Hz
10 MHz to 1.5 GHz	-86 dBc/Hz	-91 dBc/Hz	-95 dBc/Hz
1.5 GHz to 3.125 GHz	-83 dBc/Hz	-91 dBc/Hz	-95 dBc/Hz
3.125 GHz to 6.25 GHz	-77 dBc/Hz	-85 dBc/Hz	-89 dBc/Hz
6.25 GHz to 12.5 GHz	-71 dBc/Hz	-79 dBc/Hz	-83 dBc/Hz
12.5 GHz to 20 GHz	-65 dBc/Hz	-73 dBc/Hz	-77 dBc/Hz

Table 9. Test Port Input

Description	Specification		Typical	
	Options 240, 245		Options 240, 245	
Test Port Noise Floor				
Total average (rms) noise power calculated as the mean value of a linear magnitude trace expressed in dBm.				
10 Hz IF Bandwidth				
300 KHz to 10 MHz	--		<-103 dBm	
10 MHz to 500 MHz	<-112 dBm		<-116 dBm	
500 MHz to 4 GHz	<-112 dBm		<-120 dBm	
4 GHz to 10.5 GHz	<-112 dBm		<-119 dBm	
10.5 GHz to 15 GHz	<-107 dBm		<-114 dBm	
15 GHz to 20 GHz	<-106 dBm		<-114 dBm	
1 KHz IF Bandwidth				
300 KHz to 10 MHz	--		<-83 dBm	
10 MHz to 500 MHz	<-92 dBm		<-96 dBm	
500 MHz to 4 GHz	<-92 dBm		<-100 dBm	
4 GHz to 10.5 GHz	<-92 dBm		<-99 dBm	
10.5 GHz to 15 GHz	<-87 dBm		<-94 dBm	
15 GHz to 20 GHz	<-86 dBm		<-94 dBm	
Direct Receiver Access Input Noise Floor (Option 245 Only)				
Total average (rms) noise power calculated as the mean value of a linear magnitude trace expressed in dBm.				
10 Hz IF Bandwidth				
300 KHz to 10 MHz	--		<-119 dBm	
10 MHz to 500 MHz	<-128 dBm		<-132 dBm	
500 MHz to 4 GHz	<-128 dBm		<-136 dBm	
4 GHz to 10.5 GHz	<-128 dBm		<-135 dBm	
10.5 GHz to 15 GHz	<-123 dBm		<-130 dBm	
15 GHz to 20 GHz	<-122 dBm		<-130 dBm	
1 KHz IF Bandwidth				
300 KHz to 10 MHz	--		<-99 dBm	
10 MHz to 500 MHz	<-108 dBm		<-112 dBm	
500 MHz to 4 GHz	<-108 dBm		<-116 dBm	
4 GHz to 10.5 GHz	<-108 dBm		<-115 dBm	
10.5 GHz to 15 GHz	<-103 dBm		<-110 dBm	
15 GHz to 20 GHz	<-102 dBm		<-110 dBm	
Description	Specification		Typical	
	Options 240, 245		Options 240, 245	
Compression Level (at +8 dBm except as noted)				
	Power	Com- pression	Power	Com- pression
300 KHz to 10 MHz	--	--	+5 dBm	0.10 dB
10 MHz to 50 MHz	+8 dBm	0.35 dB	--	--
50 MHz to 1 GHz	+8 dBm	0.35 dB	--	--
1 GHz to 8 GHz	+8 dBm	0.25 dB	--	--
8 GHz to 12.5 GHz	+8 dBm	0.30 dB	--	--
12.5 GHz to 20 GHz	+8 dBm	0.55 dB	--	--
Test Port Compression - 0.1 dB				
300 KHz to 10 MHz	--	--	+5 dBm	--
10 MHz to 1 GHz	--	--	+9 dBm	--
1 GHz to 12.5 GHz	--	--	+10 dBm	--
12.5 GHz to 20 GHz	--	--	+9 dBm	--

Table 9. Test Port Input (Continued)

Description	Specification		Typical	
	Option 240	Option 245	Option 240	Option 245
Trace Noise Magnitude				
Ratioed measurement, nominal power at test port.				
100 KHz IF bandwidth				
300 KHz to 10 MHz	--	--	.015 dB rms	.030 dB rms
10 MHz to 10.5 GHz	.006 dB rms	.008 dB rms	.004 dB rms	.005 dB rms
10.5 GHz to 20 GHz	.010 dB rms	.014 dB rms	.007 dB rms	.009 dB rms
600 KHz IF bandwidth				
300 KHz to 10 MHz	--	--	.015 dB rms	.030 dB rms
10 MHz to 10.5 GHz	--	--	.013 dB rms	.015 dB rms
10.5 GHz to 20 GHz	--	--	.017 dB rms	.023 dB rms
100 KHz IF bandwidth				
Measured at Maximum Specified Power				
300 KHz to 10 MHz	--	--	.005 dB rms	.010 dB rms
10 MHz to 2 GHz	--	--	.001 dB rms	.003 dB rms
2 GHz to 10.5 GHz	--	--	.002 dB rms	.003 dB rms
10.5 GHz to 20 GHz	--	--	.006 dB rms	.009 dB rms
Trace Noise Phase				
Ratioed measurement, nominal power at test port.				
100 KHz IF bandwidth				
300 KHz to 10 MHz	--	--	0.110 deg rms	0.180 deg rms
10 MHz to 10.5 GHz	0.05 deg rms	0.07 deg rms	0.025 deg rms	0.035 deg rms
10.5 GHz to 20 GHz	0.08 deg rms	0.10 deg rms	0.050 deg rms	0.060 deg rms
600 KHz IF bandwidth				
300 KHz to 10 MHz	--	--	0.110 deg rms	0.180 deg rms
10 MHz to 10.5 GHz	--	--	0.080 deg rms	0.100 deg rms
10.5 GHz to 20 GHz	--	--	0.120 deg rms	0.160 deg rms
100 KHz IF bandwidth				
Measured at Maximum Specified Power				
300 KHz to 10 MHz	--	--	0.040 deg rms	0.050 deg rms
10 MHz to 2 GHz	--	--	0.007 deg rms	0.012 deg rms
2 GHz to 10.5 GHz	--	--	0.012 deg rms	0.015 deg rms
10.5 GHz to 20 GHz	--	--	0.040 deg rms	0.060 deg rms
Reference Level Magnitude				
Range	+/-200 dB	+/-200 dB	--	--
Resolution	0.001dB	0.001dB	--	--
Reference Level Phase				
Range	+/-500°	+/-500°	--	--
Resolution	0.01°	0.01°	--	--
Stability Magnitude				
Stability is defined as a ratio measurement made at the test port.				
300 KHz to 10 MHz	--	--	+/-0.015 dB/°C	
10 MHz to 2 GHz	--	--	+/-0.010 dB/°C	
2 GHz to 4 GHz	--	--	+/-0.015 dB/°C	
4 GHz to 16 GHz	--	--	+/-0.020 dB/°C	
16 GHz to 19 GHz	--	--	+/-0.025 dB/°C	
19 GHz to 20 GHz	--	--	+/-0.030 dB/°C	

Table 9. Test Port Input (Continued)

Description	Specification		Typical	
	Option 240	Option 245	Option 240	Option 245
Stability Phase				
Stability is defined as a ratio measurement made at the test port.				
300 KHz to 10 MHz	--	--	+/-0.360°/°C	
10 MHz to 45 MHz	--	--	+/-0.020°/°C	
45 MHz to 500 MHz	--	--	+/-0.030°/°C	
500 MHz to 2 GHz	--	--	+/-0.050°/°C	
2 GHz to 4 GHz	--	--	+/-0.100°/°C	
4 GHz to 8 GHz	--	--	+/-0.150°/°C	
8 GHz to 16 GHz	--	--	+/-0.300°/°C	
16 GHz to 20 GHz	--	--	+/-0.350°/°C	

Table 9. Test Port Input (Continued)

Damage Input Level	Typical Performance	
	Opt 240	Opt 245
Test Port 1,2,3, and 4	+27 dBm or +/-16 VDC	+27 dBm or +/-16 VDC
Receivers R, A, B, C, D	--	+15 dBm or +/-16 VDC
Source out (reference)	--	+27 dBm or +/-16 VDC
Source out (test ports)	--	+27 dBm or +/-16 VDC
Coupler Thru	--	+27 dBm or +/-16 VDC
Coupler Arm	--	+15 dBm or +/-0 VDC

Table 10. Dynamic Accuracy (Specification^a)

Accuracy of the test port input power reading relative to the reference input power level.

Dynamic Accuracy, 0.045 GHz

Magnitude

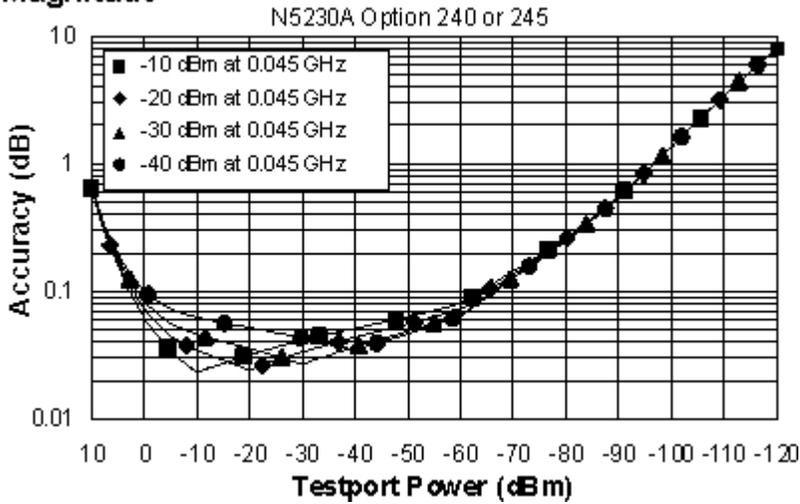

Phase

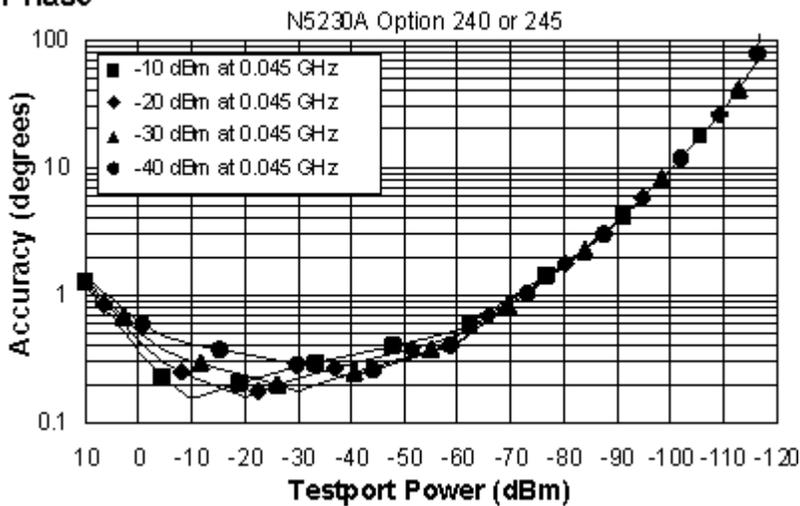

^a Dynamic accuracy is verified with the following measurements:

- Compression over frequency
- IF linearity at a single frequency of 1.195 GHz using a reference level of -20 dBm for an input power range of 0 to -110 dBm.

Dynamic Accuracy, 0.500 GHz

Magnitude

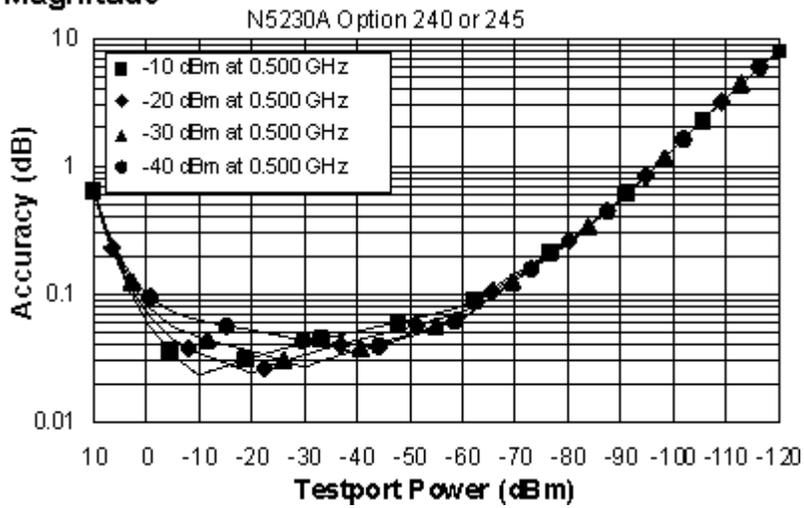

Phase

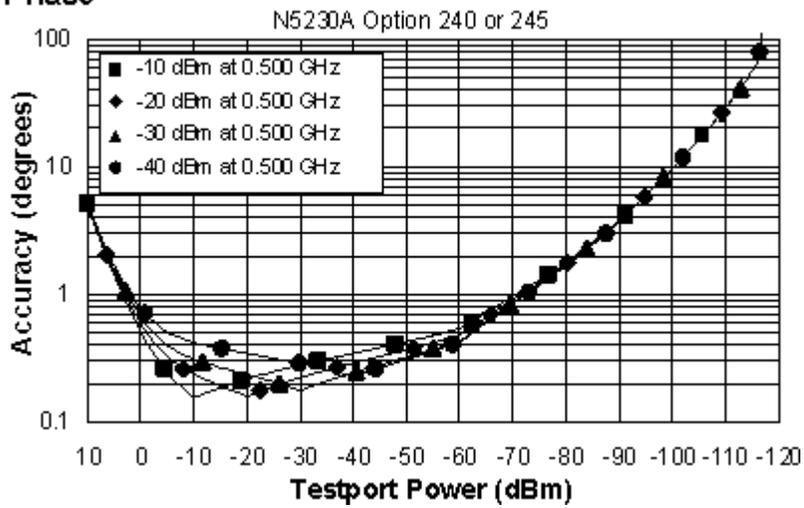

Dynamic Accuracy, 1- 2 GHz

Magnitude

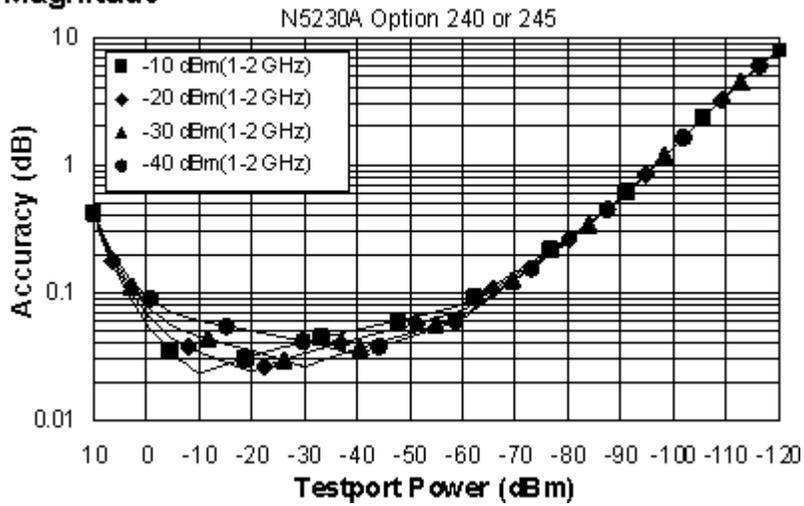

Phase

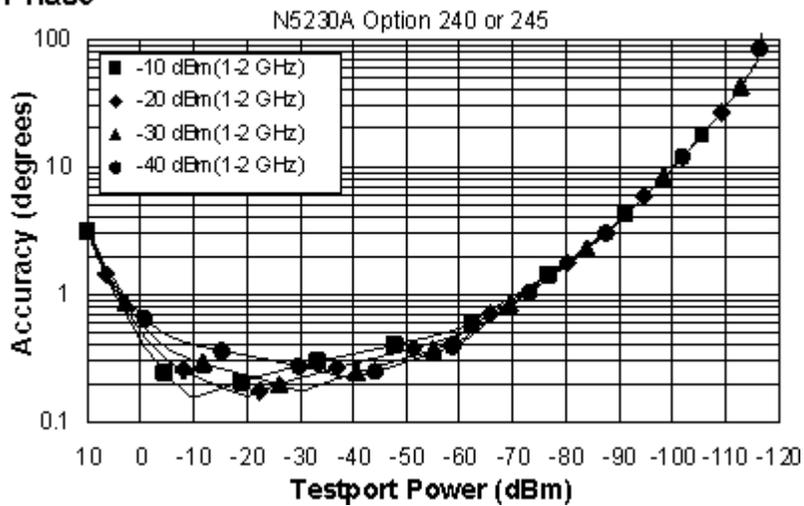

Dynamic Accuracy, 2 - 12.5 GHz

Magnitude

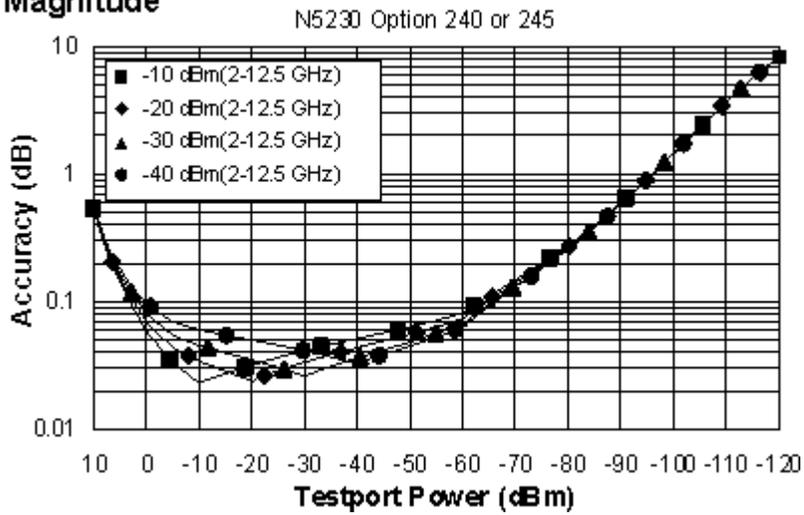

Phase

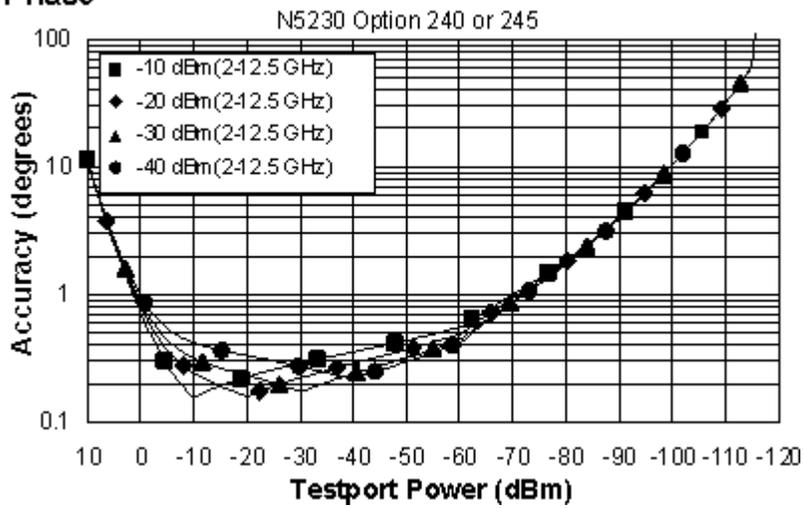

Dynamic Accuracy, 12.5 - 20 GHz

Magnitude

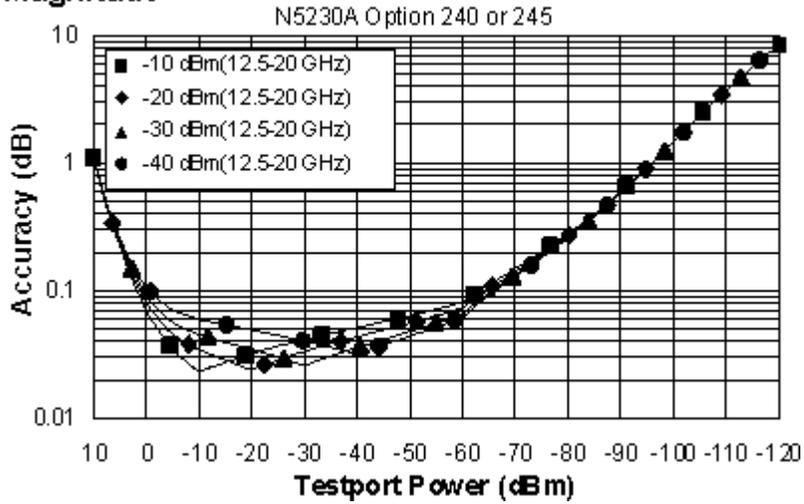

Phase

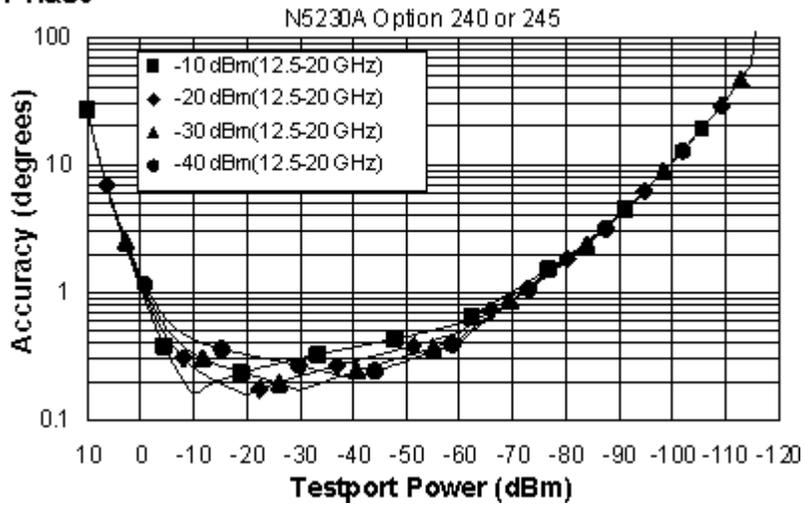

Table 11. Test Port Input (Group Delay)^a

Description	Supplemental Information (typ.)
Aperture (selectable)	(frequency span)/(number of points -1)
Maximum Aperture	20% of frequency span
Range	0.5 x (1/minimum aperture)
Maximum Delay	Limited to measuring no more than 180° of phase change within the minimum aperture.)
Accuracy	See graph below. Char.

The following graph shows characteristic group delay accuracy with full 2-port calibration and a 10 Hz IF bandwidth. Insertion loss is assumed to be < 2 dB and electrical length to be ten meters.

For any S_{ij} Group Delay measurement, $S_{ii} = 0$, $S_{ij} = 1$, $S_{ji} = 0$, $S_{kl} = 0$ for all $kl \neq ij$

Group Delay (Typical)

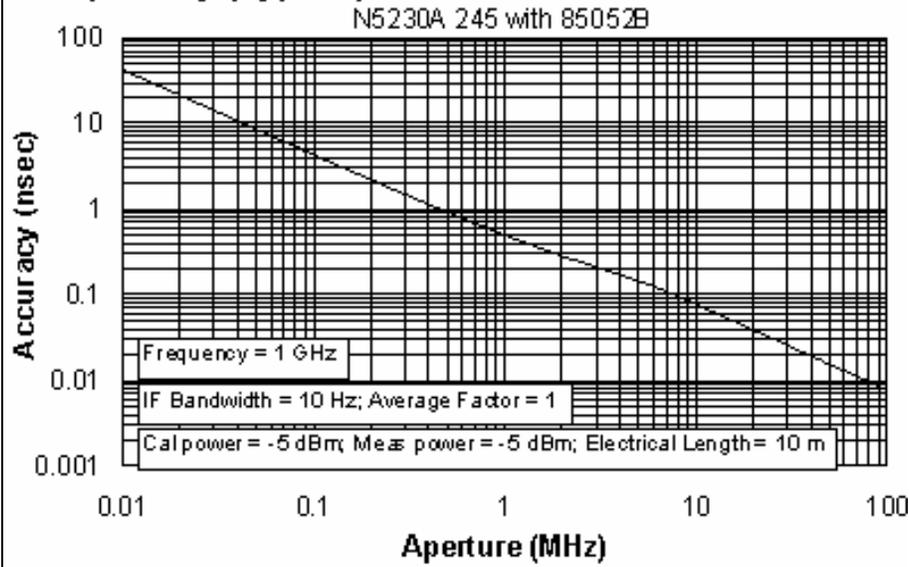

In general, the following formula can be used to determine the accuracy, in seconds, of specific group delay measurement:

$$\pm \text{Phase Accuracy (deg)} / [360 \times \text{Aperture (Hz)}]$$

Depending on the aperture and device length, the phase accuracy used is either incremental phase accuracy or worst-case phase accuracy.

^a Group delay is computed by measuring the phase change within a specified frequency step (determined by the frequency span and the number of points per sweep).

General Information

Table 12. Miscellaneous Information

Description	Supplemental Information
System IF Bandwidth Range	1 Hz to 600 kHz, nominal
CPU	Intel® 500 MHz Pentium® III

Table 13. Front Panel Information

Description	Supplemental Information
RF Connectors	
Type	Option 240 or 245: 3.5 mm (male), 50 ohm, (nominal)
Center Pin Recession	0.002 in. (characteristic)
Display	
Size	21.3 cm (8.4 in) diagonal color active matrix LCD; 640 (horizontal) X 480 (vertical) resolution
Refresh Rate	Vertical 59.83 Hz; Horizontal 31.41 kHz
Pixels	When running the analyzer's built-in Display Test, one or more of the following symptoms indicate a faulty display assembly: <ul style="list-style-type: none"> • A complete row or column of "stuck on" or "dark" pixels. • More than six "stuck on" pixels (but not more than three green) • More than twelve "dark" pixels (but not more than seven of the same color) • Two or more consecutive "stuck on" pixels or three or more consecutive "dark" pixels (but no more than one set of two consecutive 'dark' pixels) • "Stuck on" or "dark" pixels less than 6.5 mm apart (excluding consecutive pixels)
Display Range	
Magnitude	±500 dB (at 20 dB/div), max
Phase	±500°, max
Polar	10 pUnits, min 1000 Units, max
Display Resolution	
Magnitude	0.001 dB/div, min
Phase	0.01°/div, min
Marker Resolution	
Magnitude	0.001 dB, min
Phase	0.01°, min
Polar	0.01 mUnit, min; 0.01°, min

Table 14. Rear Panel Information

Description	Supplemental Information
10 MHz Reference In	
Connector	BNC, female
Input Frequency	10 MHz \pm 10 ppm, Typical
Input Level	-15 dBm to +20 dBm, Typical
Input Impedance	200 Ω , nom.
10 MHz Reference Out	
Connector	BNC, female
Output Frequency	10 MHz \pm 1 ppm, Typical
Signal Type	Sine Wave, Typical
Output Level	+10 dBm \pm 4 dB into 50 Ω , Typical
Output Impedance	50 Ω , nominal
Harmonics	<-40 dBc, Typical
VGA Video Output	
Connector	15-pin mini D-Sub; Drives VGA compatible monitors
Devices Supported	Resolutions:
Flat Panel (TFT)	1024 X 768, 800 X 600, 640 X 480
Flat Panel (DSTN)	800 X 600, 640 X 480
CRT Monitor	1280 X 1024, 1024 X 768, 800 X 600, 640 X 480
	Simultaneous operation of the internal and external displays is allowed, but with 640 X 480 resolution only. If you change resolution, you can only view the external display (internal display will "white out").
Test Set IO	
	25-pin D-Sub connector, female, available for external test set control
Aux IO	
	25-pin D-Sub connector, male, analog and digital IO
Handler IO	
	36-pin parallel I/O port; all input/output signals are default set to negative logic; can be reset to positive logic via GPIB command female.
GPIB	
	24-pin D-sub (Type D-24), female; compatible with IEEE-488.
Parallel Port (LPT1)	
	25-pin D-Sub miniature connector, female; provides connection to printers or any other parallel port peripherals
Serial Port (COM 1)	
	9-pin D-Sub, male; compatible with RS-232
USB Port	
	One port on front panel and five ports on rear panel. Universal Serial Bus jack, Type A configuration (4 contacts inline, contact 1 on left); female
Contact 1	Vcc: 4.75 to 5.25 VDC, 500 mA, maximum
Contact 2	-Data
Contact 3	+Data
Contact 4	Ground
LAN	
	10/100BaseT Ethernet, 8-pin configuration; auto selects between the two data rates
Line Power (A third-wire ground is required.)	
Frequency	48 Hz to 66 Hz
Voltage at 115 V Setting	90 to 132 VAC; 120 VAC, nominal
Voltage at 220 V Setting	198 to 264 VAC; 240 VAC, nominal
VA Max	600 VA maximum

Note: Option H08 and Option H11 are not available with the N5230A network analyzer.

Table 15. Analyzer Environment and Dimensions

Description	Supplemental Information		
General Environmental			
RFI/EMI Susceptibility	Defined by CISPR Pub. 11, Group 1, Class A, and IEC 50082-1		
ESD	Minimize using static-safe work procedures and an antistatic bench mat		
Dust	Minimize for optimum reliability		
Operating Environment			
Temperature	0 °C to +40 °C Instrument powers up and displays no error messages within this temperature range (except for "source unlevelled" error message that may occur at temperatures outside the specified performance temperature range of 25 +/- 5°C).		
Error-Corrected Temperature Range	23°C ± 3°C with less than 1°C deviation from calibration temp.		
Humidity	5% to 95% at +40 °C		
Altitude	0 to 4500 m (14,760 ft.)		
Non-Operating Storage Environment			
Temperature	-40 °C to +70 °C		
Humidity	0% to 90% at +65 °C (non-condensing)		
Altitude	0 to 4500 m (14,760 ft.)		
Cabinet Dimensions			
	Height	Width	Depth
Excluding front and rear panel hardware and feet	267 mm 10.5 in	426 mm 16.75 in	427 mm 16.8 in
As shipped - includes front panel connectors, rear panel bumpers, and feet.	280 mm 11.0 in	435 mm 17.1 in	470 mm 18.5 in
As shipped plus handles	280 mm 11.0 in	458 mm 18 in	501 mm 19.7 in
As shipped plus rack-mount flanges	280 mm 11.0 in	483 mm 19 in	470 mm 18.5 in
As shipped plus handles and rack-mount flanges	280 mm 11.0 in	483 mm 19 in	501 mm 19.70 in
Weight			
Net	24.9 kg (55 lb), nominal		
Shipping	36.3 kg (80 lb), nominal		

Measurement Throughput Summary

Table 16 Typical Cycle Time^a (ms) for Measurement Completion

Description	Typical Performance				
	Number of Points				
	201	401	801	1601	16,001
Start 8 GHz, Stop 18 GHz, 600 kHz IF bandwidth					
Uncorrected	26.2	26.7	27.6	29.2	76.5
4-Port cal	93.0	104.1	125.2	164.0	939.6
Start 300 kHz, Stop 10 GHz, 600 kHz IF bandwidth					
Uncorrected	24.8	28.0	30.4	35.0	91.8
4-Port cal	87.5	109.0	134.6	180.5	990.8
Start 300 kHz, Stop 20 GHz, 600 kHz IF bandwidth					
Uncorrected	38.3	40.2	43.6	46.6	93.8
4-Port cal	140.2	158.3	190.0	224.2	1012.3
Start 8 GHz, Stop 18 GHz, 100 kHz IF bandwidth					
Uncorrected	43.1	56.9	60.9	62.1	193.4
4-Port cal	160.4	222.2	248.8	274.5	1291.1
Start 300 kHz, Stop 10 GHz, 100 kHz IF bandwidth					
Uncorrected	41.8	48.3	51.1	53.7	209.9
4-Port cal	155.1	180.0	214.2	260.5	1362.7
Start 300 kHz, Stop 20 GHz, 100 kHz IF bandwidth					
Uncorrected	51.4	76.4	94.0	99.8	211.4
4-Port cal	190.3	292.4	379.8	419.8	1378.7
Start 8 GHz, Stop 18 GHz, 50 kHz IF bandwidth					
Uncorrected	47.1	75.1	94.6	97.3	380.9
4-Port cal	171.6	290.1	381.0	410.0	1894.4
Start 300 kHz, Stop 10 GHz, 50 kHz IF bandwidth					
Uncorrected	49.1	67.2	72.7	75.9	395.1
4-Port cal	180.0	261.4	293.1	330.6	1941.2
Start 300 kHz, Stop 20 GHz, 50 kHz IF bandwidth					
Uncorrected	54.9	87.1	131.2	154.4	396.3
4-Port cal	207.0	337.7	523.9	633.6	1948.2

^a Includes sweep time, retrace time and band-crossing time. Analyzer display turned off with DISPLAY:ENABLE OFF. Add 21 ms for display on. Data for one trace (S₁₁) measurement.

Table 17. Cycle Time vs. IF Bandwidth

Applies to the Preset condition (201 points, correction off) except for the following changes:

- CF = 10 GHz
- Span = 100 MHz
- Display off (add 21 ms for display on)

Description	Typical Performance	
	IF Bandwidth (Hz)	Cycle Time (ms) ^a
600,000	7.523394495	0.003533948
360,000	7.54179941	0.002688865
280,000	7.5703125	0.002287365
200,000	7.71344	0.002102872
150,000	7.762206897	0.001696417
100,000	7.806733333	0.001284263
70,000	7.874966555	0.001170092
50,000	9.076777778	0.000987238
30,000	11.46182377	0.0008445
20,000	14.72636574	0.000647383
15,000	17.5863125	0.000534657
10,000	28.64310448	0.000477914
7000	37.16706481	0.000439644
5000	48.58746512	0.000350175
3000	72.52639344	0.00030881
2000	102.2277778	0.000279538
1500	130.7245	0.00015128
1000	218.5535	0.000154337
700	294.1385333	0.000135211
500	399.9245455	0.000125675
300	636.411	0.000103409
200	932.7632	0
100	1826.966667	0
30	6004.446	0
10	17903.564	0
1	178398.611	0

^a Cycle time includes sweep and retrace time.

Table 18. Cycle Time vs. Number of Points

Applies to the Preset condition (correction off) except for the following changes:

- CF = 10 GHz
- Span = 100 MHz
- Display off (add 21 ms for display on)

Description	Typical Performance	
	Number of Points	Cycle Time (ms) ^a
30,000	3	6.7
	11	7.4
	51	6.9
	101	7.8
	201	11.2
	401	18.3
	801	32.4
	1,601	59.4
	6,401	224.7
	16,001	556.9
100,000	3	6.7
	11	6.6
	51	6.8
	101	7
	201	7.5
	401	9
	801	13.5
	1,601	22.9
	6,401	75.3
	16,001	180.3
600,000	3	6.5
	11	6.6
	51	6.8
	101	6.9
	201	7.3
	401	8.1
	801	9.4
	1,601	12
	6,401	27.7
	16,001	59.3

^a Cycle time includes sweep and retrace time.

Table 19. Data Transfer Time (ms)

Description	Typical Performance			
	Number of Points			
	201	401	1601	16,001
SCPI over GPIB				
(Program executed on external PC)				
32-bit floating point	7	12	43	435
64-bit floating point	12	22	84	856
ASCII	64	124	489	5054
SCPI				
(Program executed in the analyzer)				
32-bit floating point	1	2	3	30
64-bit floating point	2	2	4	40
ASCII	29	56	222	2220
COM (program executed in the analyzer)				
32-bit floating point	<0.4	0.4	0.5	1.9
Variant type	0.7	1	3	32
DCOM over LAN				
(Program executed on external PC)				
32-bit floating point	<0.8	1	1.5	7.1
Variant type	1.8	2.7	8.5	80

Note: Specifications for Recall & Sweep Speed are not provided for the N5230A analyzers.

Specifications: Front-Panel Jumpers

Model N5230A Option 245

Table 20: Measurement Receiver Inputs (Rcvr A In, Rcvr B In, Rcvr C In, Rcvr D In) 0.1dB Typical Compression

Description	Specification	Typical
		Option 245
Maximum Input Level		
300 kHz to 10 MHz	--	- 11 dBm
10 MHz to 1 GHz	--	- 7 dBm
1 GHz to 12.5 GHz	--	- 6 dBm
12.5 GHz to 20 GHz	--	- 7 dBm
Damage Level		
N5230A	--	+ 15 dBm
Maximum DC Level		
N5230A	--	+/- 16 V

Table 21: Reference Receiver Input (Rcvr In) @ Max Specified Output Power

Description	Specification	Typical
		Option 245
Maximum Input Level		
300 kHz to 10 MHz	--	- 15 dBm
10 MHz to 45 MHz	--	- 15 dBm
45 MHz to 500 MHz	--	- 15 dBm
500 MHz to 4 GHz	--	- 15 dBm
4 GHz to 6 GHz	--	- 16 dBm
6 GHz to 10.5 GHz	--	- 20 dBm
10.5 GHz to 15 GHz	--	- 21 dBm
15 GHz to 20 GHz	--	- 27 dBm
Damage Level		
N5230A	--	+ 15 dBm
Maximum DC Level		
N5230A	--	+/- 16 V

Table 22: Reference Output (Source Out) @ Max Specified Output Power

Description	Specification	Typical
		Option 245
Maximum Output Level		
300 kHz to 10 MHz	--	- 15 dBm
10 MHz to 45 MHz	--	- 15 dBm
45 MHz to 500 MHz	--	- 15 dBm
500 MHz to 4 GHz	--	- 15 dBm
4 GHz to 6 GHz	--	- 15 dBm
6 GHz to 10.5 GHz	--	- 20 dBm
10.5 GHz to 15 GHz	--	- 21 dBm
15 GHz to 20 GHz	--	- 27 dBm
Damage Level		
N5230A	--	+ 27 dBm
Maximum DC Level		
N5230A	--	+/- 16 V

Table 23: Source Outputs (Port 1 Source Out, Port 2 Source Out, Port 3 Source Out, Port 4 Source Out) @ Max Specified Output Power

Description	Specification	Typical
		Option 245
Maximum Output Level		
300 kHz to 10 MHz	--	+10 dBm
10 MHz to 45 MHz	--	+ 10 dBm
45 MHz to 500 MHz	--	+ 10 dBm
500 MHz to 4 GHz	--	+ 10 dBm
4 GHz to 6 GHz	--	+ 9 dBm
6 GHz to 10.5 GHz	--	+ 4 dBm
10.5 GHz to 15 GHz	--	+ 1 dBm
15 GHz to 20 GHz	--	- 4 dBm
Damage Level		
N5230A	--	+ 27 dBm
Maximum DC Level		
N5230A	--	+/- 16V

Table 24: Coupler Inputs (Port 1 Cplr Thru, Port 2 Cplr Thru, Port 3 Cplr Thru, Port 4 Cplr Thru)
Insertion Loss of Coupler Thru

Description	Specification	Typical
		Option 245
Insertion Loss to Test Port		
300 kHz to 10 MHz		1.5 dB
10 MHz to 45 MHz	--	1.5 dB
45 MHz to 500 MHz	--	1.5 dB
500 MHz to 4 GHz	--	2.0 dB
4 GHz to 6 GHz	--	2.5 dB
6 GHz to 10.5 GHz	--	2.5 dB
10.5 GHz to 15 GHz	--	3.0 dB
15 GHz to 20 GHz	--	3.0 dB
Damage Level		
N5230A	--	+ 27 dBm
Maximum DC Level		
N5230A	--	+/- 16 V

Table 25: Coupler Outputs (Port 1 Cplr Arm, Port 2 Cplr Arm, Port 3 Cplr Arm, Port 4 Cplr Arm)

Description	Specification	Typical
		Option 245
Damage Level		
N5230A	--	+ 15 dBm
Maximum DC Level		
N5230A	--	0 V

Test Set Block Diagrams

N5230A Option 240 (Standard Test Set and Standard Power Range)

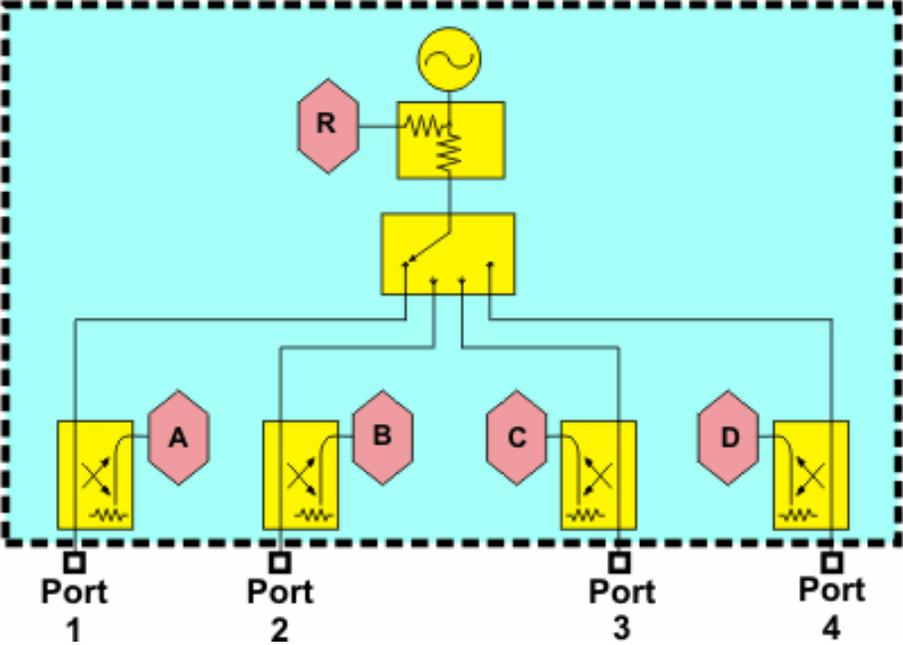

N5230A Option 245 (Configurable Test Set and Extended Power Range)

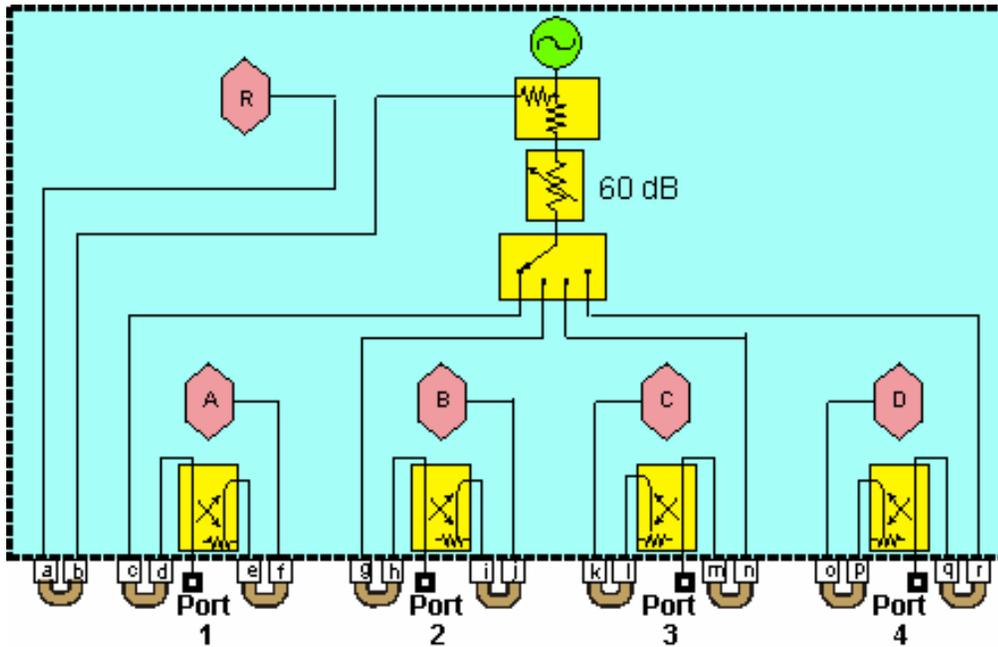

Item	Description	Item	Description	Item	Description
a	RCVR R IN	h	CPLR THRU	o	RCVR D IN
b	SOURCE OUT	i	CPLR ARM	p	CPLR ARM
c	SOURCE OUT	j	RCVR B IN	q	CPLR THRU
d	CPLR THRU	k	RCVR C IN	r	SOURCE OUT
e	CPLR ARM	l	CPLR ARM		
f	RCVR A IN	m	CPLR THRU		
g	SOURCE OUT	n	SOURCE OUT		